



**ELPRA SA**  
**ELECTRONIC PRAXIS**

---

INDUSTRIAL AREA OF THERMI  
PO BOX 355 THERMI 57001  
THESSALONIKI GREECE  
<http://www.elpra.com>

Tel +30 31 46 40 22  
Fax +30 31 46 46 07  
e-mail [info@elpra.com](mailto:info@elpra.com)

**Direct Bus :**

**Distributed Reduced Cost T field  
bus system**

**Dr G. Sergiadis**

# DATA MONITORING

## 1. >10 years ago

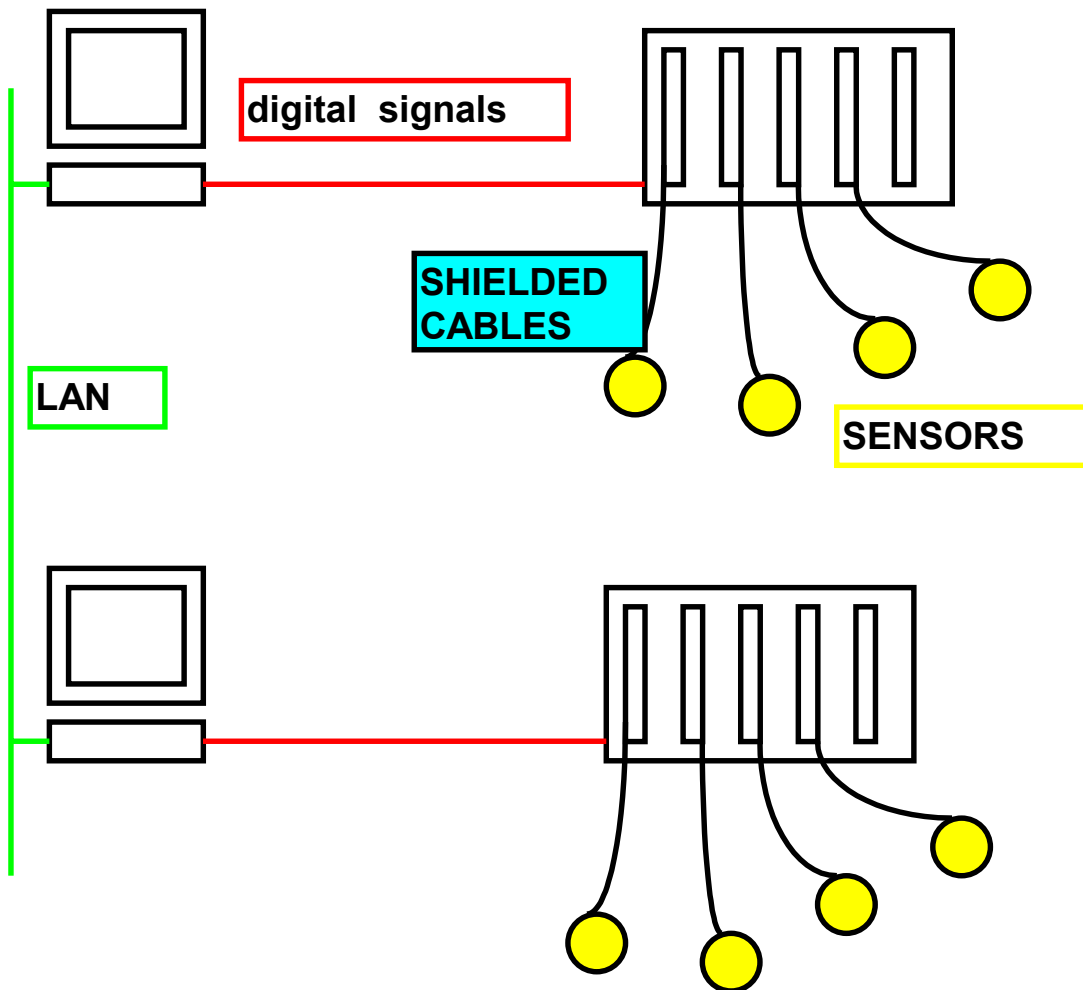

2. > 5 years ago

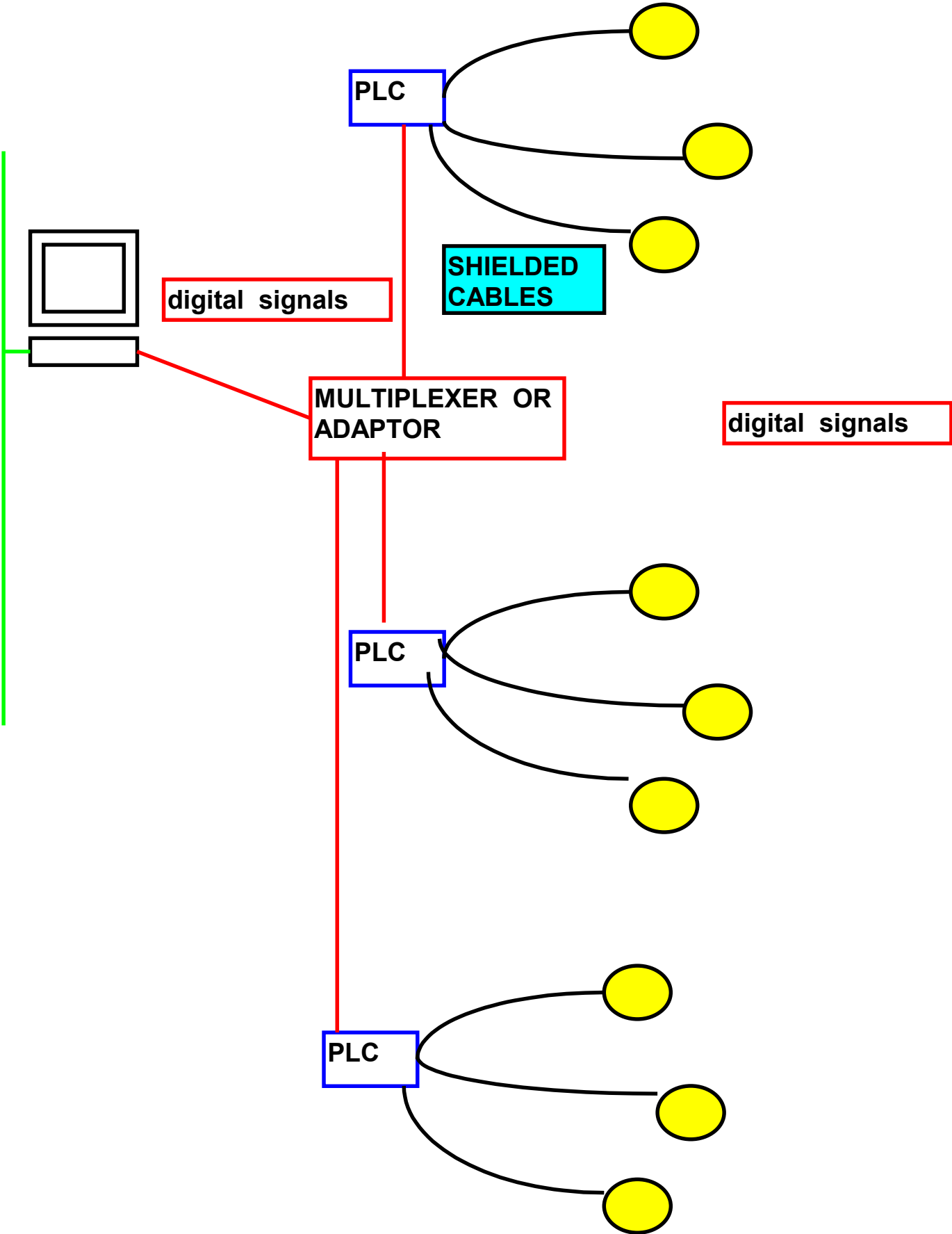

### 3. Actual and > 2 years ago

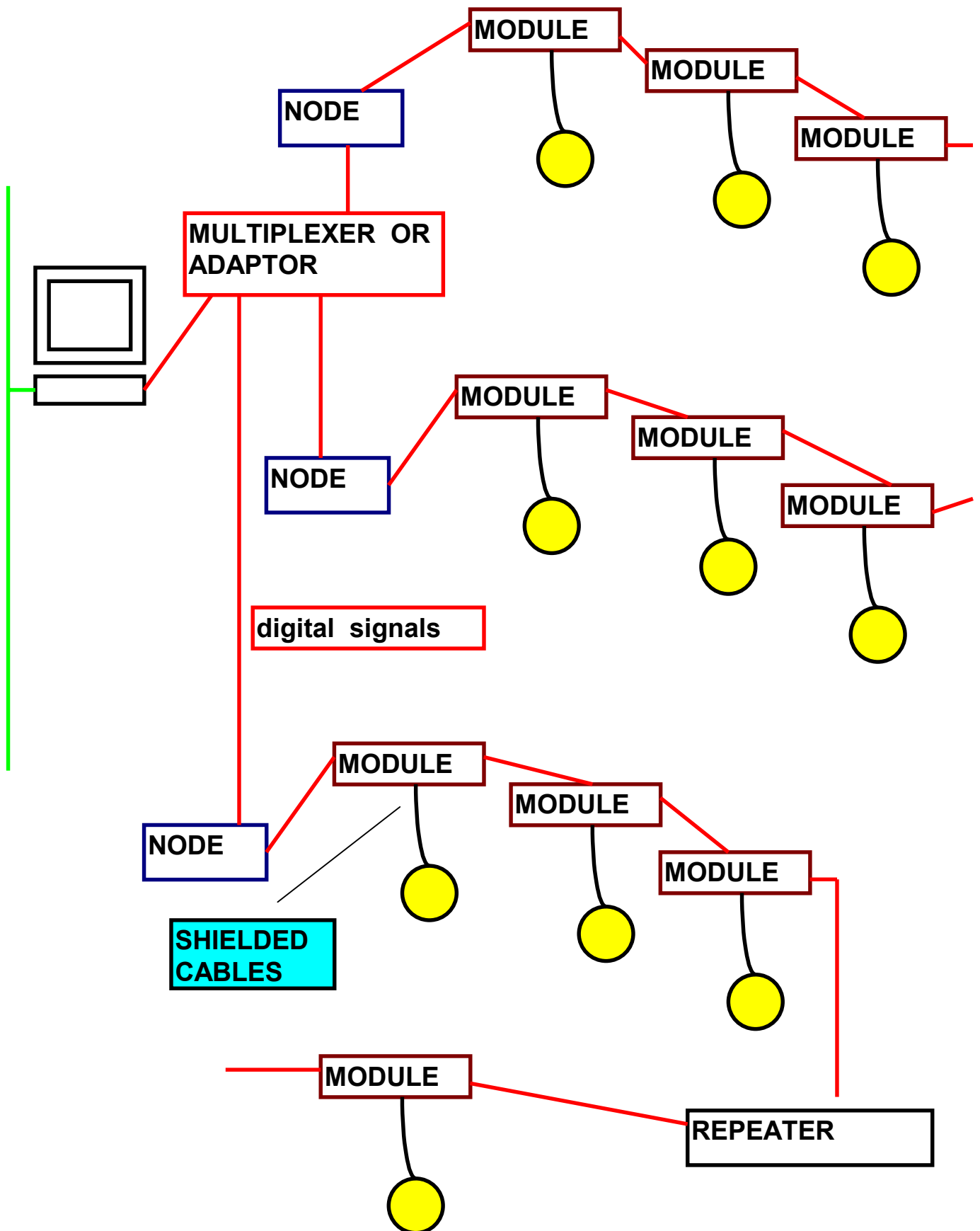

## 4. Digital Information Channels

### Time division Multiplexing

Nth module packet



→  
TIME



→  
TIME

# 5.Information throughput efficiency ITE



$$\text{ITE} = \frac{\text{INFORMATION}}{\text{TOTAL PACKET}}$$



**BUS SPEED // E M I**

## **6. Bus system variations**

**1. Sequential, random, or priority driven information exchange**

**2. Master - slave  
Listener - Talker**

**3. Auto configuration systems**

**4. Support Software**

## **7. Optimisation**

**1. High number of sensors**

**2. Cabling problems**

**3. EMI**

**4. Sampling speed**

**5. Security check**

**6. Cost**



# 8. Direct Bus

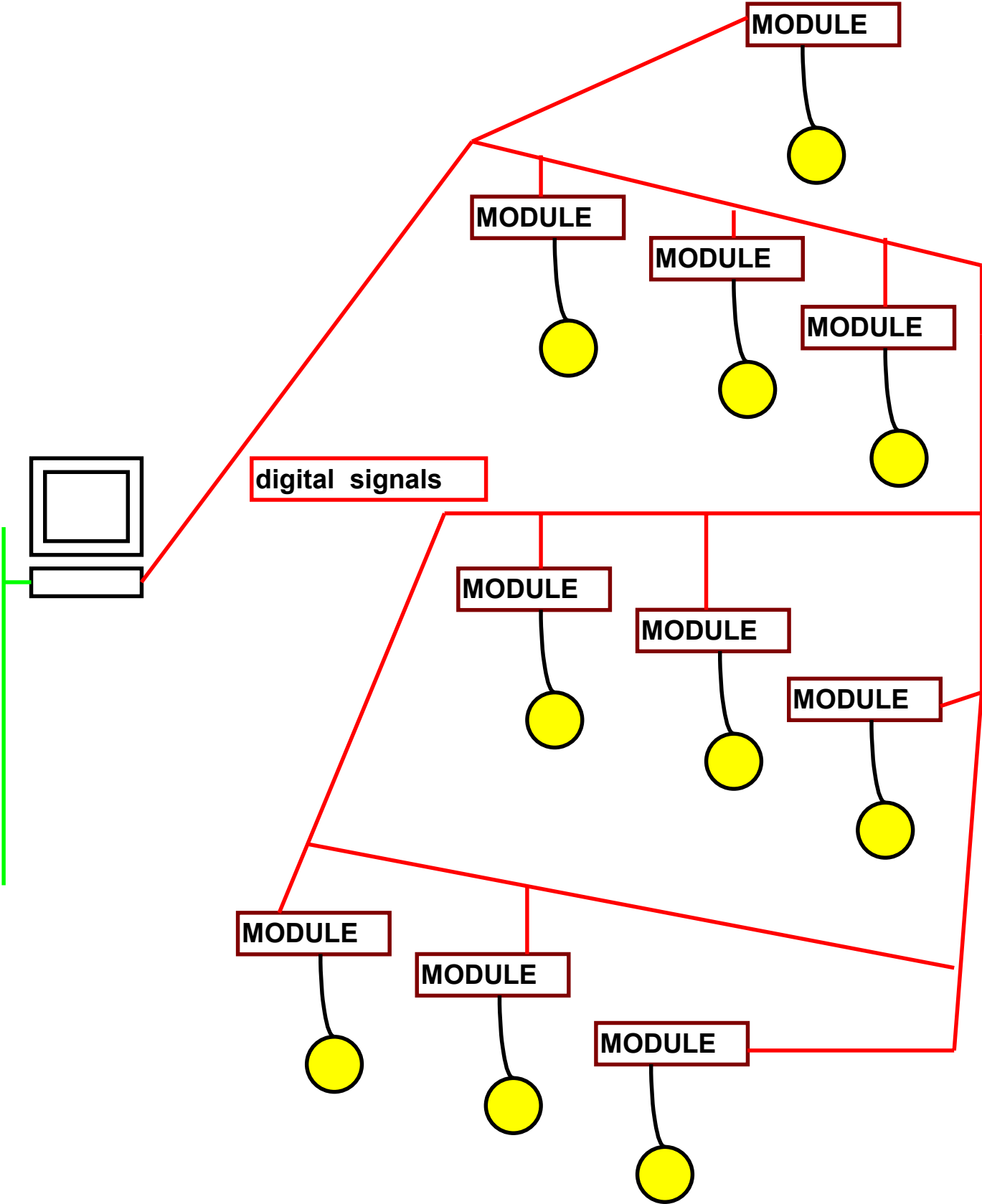

## **9. Direct Bus Principles**

### **1. Sequential addressing**

**All modules are visited at each cycle sequentially**

**2. Module Identification, Data input, Data output, in combined software and hardware mode**

**3. Each module = one controller with integrated a/d or d/a or dig I/Os and discrete components**

### **4. Advantages :**

**High ITE,**

**Possible experiment synchronisation,**

**Low-cost : modules, shielding and topology**

**Low EMI produced,**

**Distributed by initial design**